OWNER'S MANUAL

Mining / Offshore Beam Clamp Series



Meets ASME B30.16 specifications (certificate included)
Tested to 125% of the rated capacity

Notice

The Warnings, Cautions, and Instructions discussed in this manual cannot cover all possible conditions and situations that may occur. It must be understood by the operator that common sense and caution are factors which cannot be built into this product, but must be supplied by the operator. Persons involved with installing these clamps and / or maintaining the clamps should be well versed in this manual. Adhere to all instructions within this manual to help prevent damage and / or personal injury.

WARNING - IMPORTANT INFORMATION

Do not exceed the lift capacity of these clamps
The clamp within this manual is for industrial use only
This clamp is NOT for personnel lifting

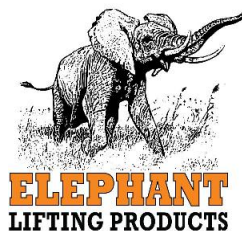

Operation:

Always check clamp for deformed parts before putting unit into use

Always be well aware of the clamp's load rating before using

Select an appropriate I-Beam, in good condition, which is capable of supporting the additional load

You may use 2 or more clamps in combination to lift objects – do not allow either lift's chain to become slack, thereby overloading the remaining clamp or clamps

Open the jaws of the clamp by rotating the handle assembly counter-clock wise. Open them enough to slip the clamp over the flanges of the I-beam.

Slip the open ends of the jaws over the flanges of the I-beam, and tighten the clamp by rotating the handle clockwise. Assure that all four jaws of the clamp are properly aligned on the flange, and are tightened securely to the beam.

Attached the lifting device to the eye bolt of the clamp

Take up the slack of the lifting chain, if applicable, and visually inspect to sure that the clamps are installed correctly; and the lift cables or chains are not twisted, kinked, or frayed.

Stand clear while the load is lifted slightly. Visually inspect that the clamps are attached properly, the load is balanced, and is safe to make the additional lift.

When the load is moved and lowered to it's proper location, provide slack in the lift cable and detach the clamps by rotating the handle assembly counter clockwise until the jaws are open enough to remove the clamp.

Clamps are meant to provide a semi permanent suspension point

Avoid side pulling

Maintenance:

The robust and simple design of these clamps will provide a long service life with minimal maintenance or repair required

Avoid damage to the screw – keep dirt and grit away from the threading while in use

Periodically open the clamp jaws all the way, and clean any contaminants from the screw threads. Apply a light coating of grease to prevent rust and provide lubrication

Protect the speed handle function form damage by keeping the lock nut fixed on the handle adaptor in either straight or 90 degree position.



Parts List for MBC Beam Clamp

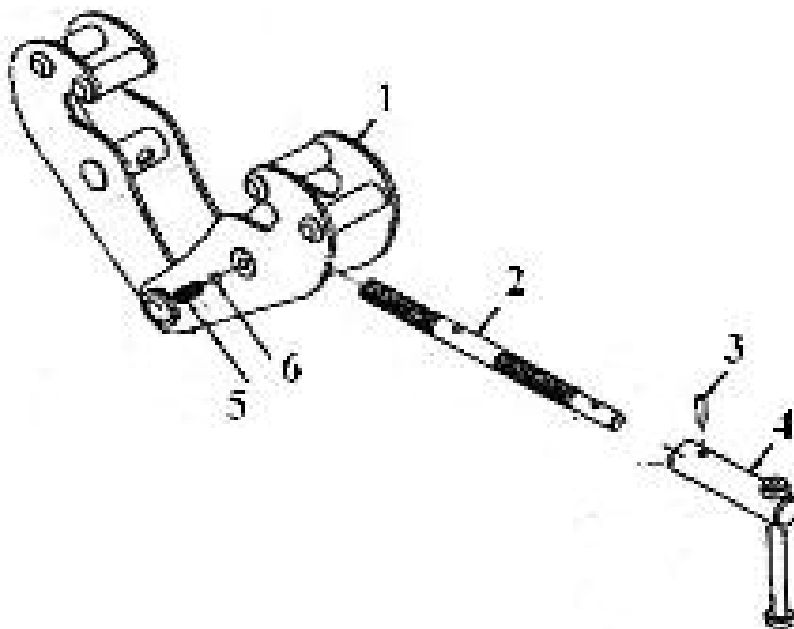

SEE NOTES BELOW WHEN ORDERING PARTS

MBC-P1	Clamp Assembly	1
MBC-P2	Spindle	1
MBC-P4	Handle Assembly	1
MBC-P5	Locked Screw	1
MBC-P6	Washer	1

When ordering parts, use the capacity of the clamp as a prefix. i.e.
1-MBC-P1 would be used when ordering the side plate assembly for a 1 ton beam clamp

