

JUMBO BEAM CLAMP

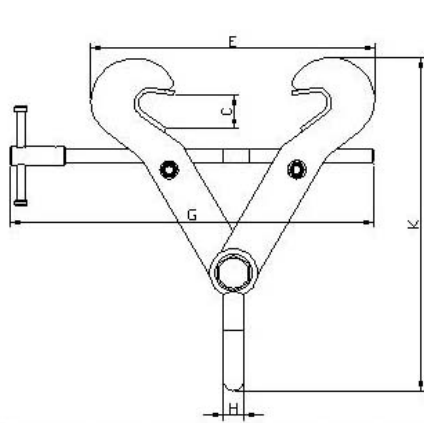

The Jumbo Beam Clamp is also a great option for your rigging application. This clamp line features a wide jaw opening for wide flange beams used throughout the industry. The JBC's clamp screw assembly is also zinc plated. This clamp series features metric capacities that range from 3, 5, 6, 10 and 16 tons.

Type	S.W.L. (lbs.)	S.W.L. US Ton	Beam Width (inch)	Dimensions (inch)										Jaw Type	Weight (lbs)
				A	B	C	D	E max	G	H	J	K min			
JBC-3	6600	3.3	3.50-12.00	5.67	0.31	1.00	4.21	16.46	16.10	0.79	3.94	12.68	Swivel	23	
JBC-3A	6600	3.3	3.00-7.48	5.12	0.55	1.06	4.21	10.71	10.87	0.79	3.35	10.00	Fixed	18	
JBC-5A	11000	6	6.00-12.00	5.51	0.55	1.81	4.80	17.72	16.10	0.98	3.90	12.56	Fixed	33	
JBC-5B	11000	6	3.00-7.48	5.12	0.55	1.81	4.80	13.39	13.35	0.98	3.90	12.99	Fixed	22	
JBC-6	13200	7	8.00-18.00	5.51	0.55	2.17	4.57	23.62	22.01	0.98	3.90	16.46	Fixed	42	
JBC-10	22000	11	8.00-18.00	5.51	0.79	2.17	4.69	23.62	22.01	1.26	3.90	16.46	Fixed	62	
JBC-10S	22000	11	3.5-12.00	5.28	0.79	1.00	4.65	13.70	16.14	1.26	4.41	15.39	Swivel	49	
JBC-16A	35000	17.6	16.00-24.00	175	20	51	130	610	810	45	200	654	Fixed	141	
JBC-16B	35000	17.6	8.00-18.00	175	20	51	130	457	660	45	200	574	Fixed	119	



Fixed Jaw

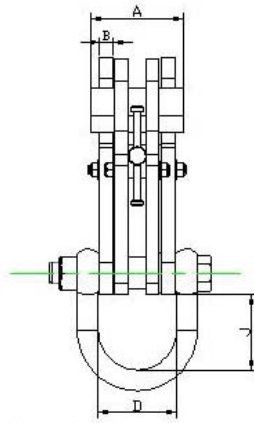

Swivel Jaw

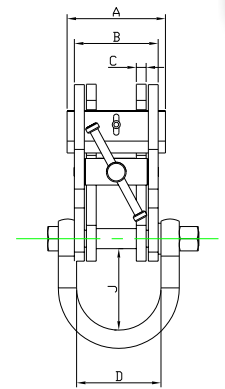
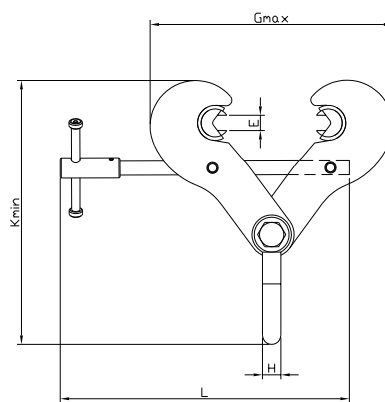

ACROSS BEAM ONLY - CLAMP MUST BE FLUSH ON BEAM WITH SHACKLE AT A ZERO DEGREE DOWN

Chart only applies to overhead beam attachment. If clamps are being used to lift beams, this information is not applicable. Table applies to the listed models only. Stress calculations should be performed by the end user's engineering dep.	Reduction in working load limits when side loads are applied				
	Angle from vertical (degree)	0	0 to 15	15 to 30	30 to 45
	Reduction Factor	NIL	17.00%	34.00%	50.00%
	Model	WLL	WLL	WLL	WLL
	JBC-3A	3 ton	2.5 ton	2 ton	1.5 ton
JBC-5A	5 ton	4.1 ton	3.3 ton	2.5 ton	
JBC-6	6 ton	5 ton	4 ton	3 ton	
JBC-10	10 ton	8.3 ton	6.6 ton	5 ton	

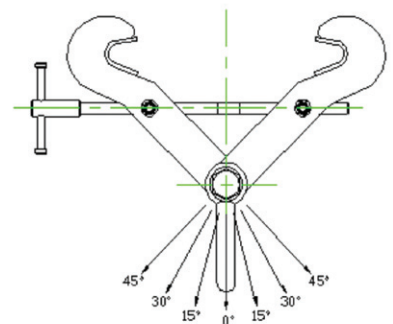

- * Warning: Clamps must be installed properly and fully tightened
- * Always contact the manufacturer when in doubt
- * Note: Clamp models JBC-3 and JBC-5B are not suitable for any side loading