

ELEPHANT

HEAVY DUTY ELECTRIC CHAIN BLOCK



DA type • DB type

SINGLE SPEED **DOUBLE SPEED**



World-Class Quality
**INDUSTRIAL
WORK HORSE
SERIES**

- Severe Duty Applications -



ELEPHANT CHAIN BLOCK CO.,LTD.

THE DA/DB SERIES **DOUBLE BRAKE** ELECTRIC CHAIN HOIST IS DESIGNED WITH OUR UNIQUE AND TRUSTABLE TECHNIQUES. THESE HOISTS ARE BUILT FOR A LIFETIME OF SERVICE, RIGID IN DESIGN, AND ARE IDEAL FOR HEAVY DUTY OPERATIONS.

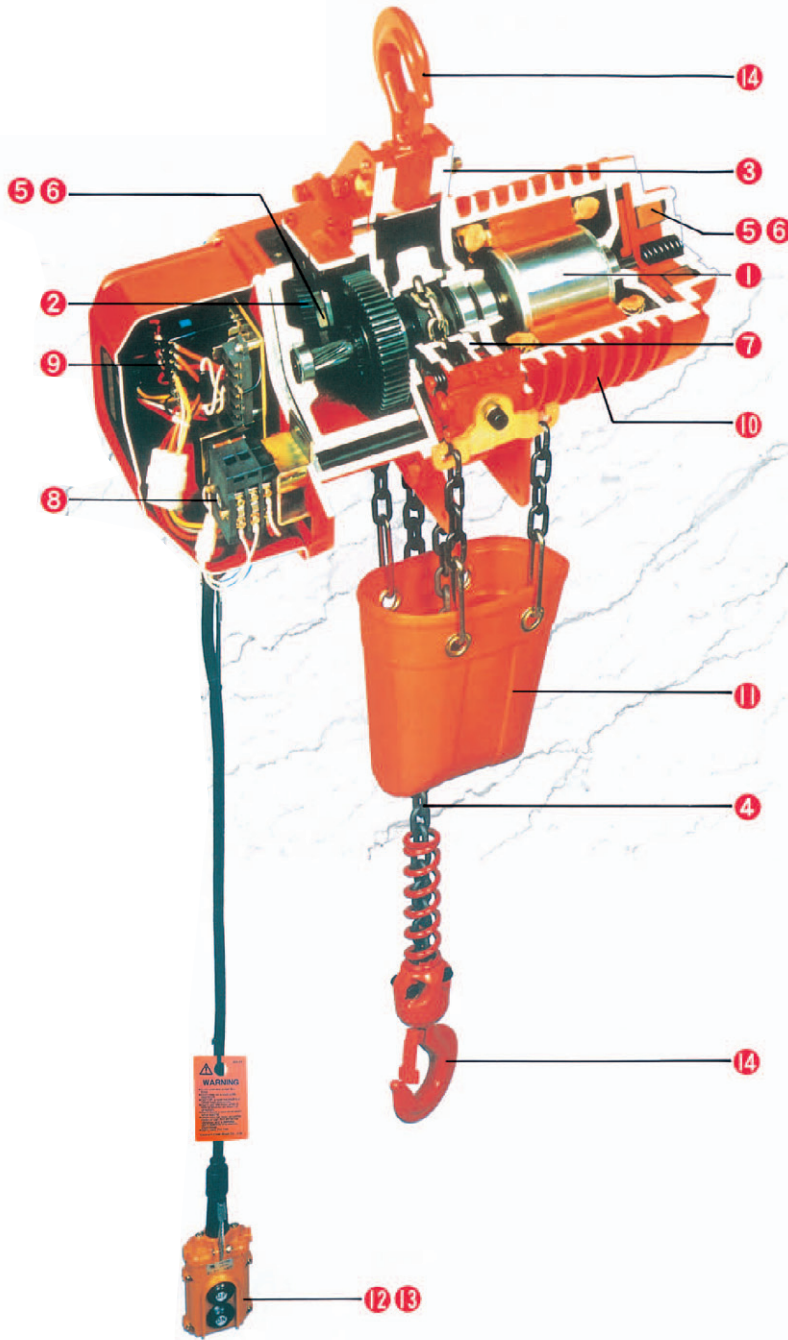

Features of the DA/DB Electric Chain Hoist

① An efficient motor that offers high lift speeds

The DA/DB series hoist features a newly developed motor for severe conditions, which allows it to operate continuously for long periods of time with frequent starts within an hour cycle. These lifting speeds were engineered to be as fast as possible to ensure efficiency.

② Quiet operation with a sealed protective body against dust

Durable helical gears & an oil bath style gear case make these units quiet during operation.

③ Solid steel side plates for a rugged heavy duty construction

④ Highly durable load chain

Our surface hardened load chain is manufactured within our factory in Osaka, Japan and is in compliance with ISO standard grade T, offering a satisfactory degree of breaking strength, wear resistance, and impact absorption. We can also offer load chain of a higher corrosion resistance upon request.

⑤ Safe DOUBLE BRAKE design

A mechanical brake and motor brake – the electric-magnetic brake is combined with a mechanical brake to constitute a complete double brake system. Even the former alone has enough capacity to hold a static safe working load!

⑥ DC brake and motor with low power consumption

A DC solenoid is used for the electro-magnetic brake. This lowers the electrical consumption throughout the operation of the electric chain hoist.

⑦ A safer chain guide with our unique design

The DA/DB series is designed so that the chain guide's rotation on the load sheave transmits to the electrical limit switch. The electric limit switch automatically stops the operation of the hoist in the event that the load chain is raised or lowered to the chain's end. In this case, the limit switch would also engage if dust or foreign matters remain pressed within the pockets of the load sheave.

⑧ Reliable double-action limit switch

Electrical limit switch for this model acts in two steps. In the first step the limit switch breaks the operating circuit. Then within the second step, the limit switch breaks the main circuit. Ensuring the hoist ceases operation.

⑨ Negative phase contactor and a highly efficient magnetic contact with a mechanical & electrical interlock

⑩ Motor frame

The motor frame is constructed with high quality aluminum cooling fins which help reduce the rise of temperature within the motor

⑪ Durable chain container

⑫ Pendant control switch is set at 24v for safe operation

⑬ Push-push button style pendant for the DB models

⑭ Top and bottom hooks with safety latch

Designed to gradually open and not break suddenly in the event of an overload. A compact thrust bearing also helps to prevent the load chain from twisting.





ELECTRIC CHAIN BLOCK

HOOK SUSPENSION TYPE

2 push button type (DA·DB)

2 push button type (DA)

2 push button type (DB)

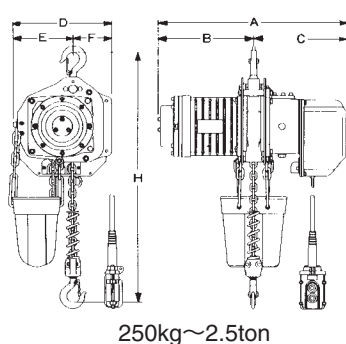
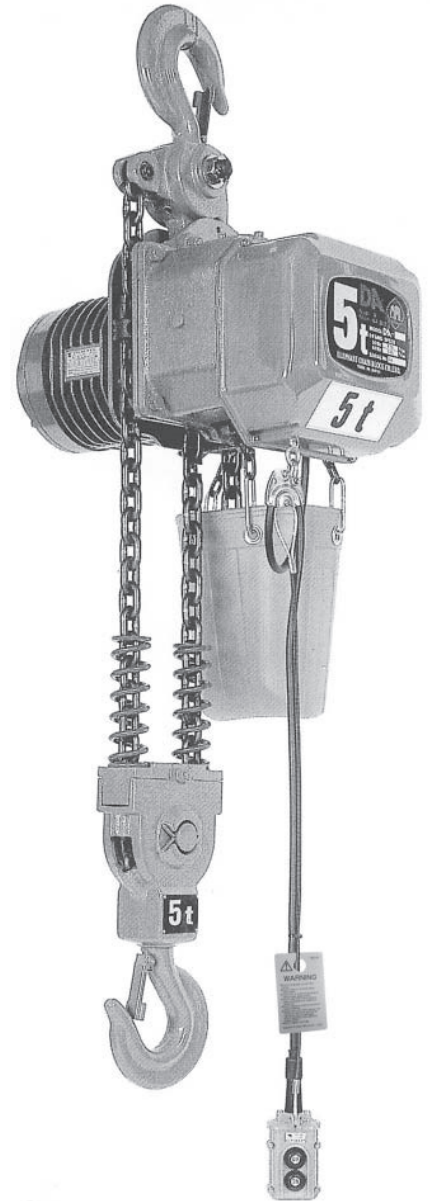

250kg~2.5ton

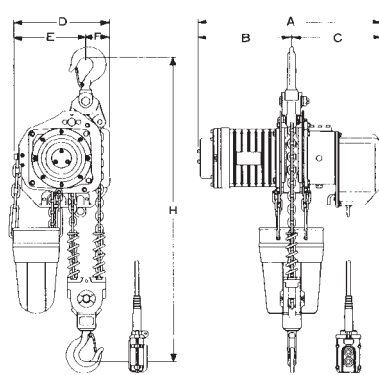

1t~5ton

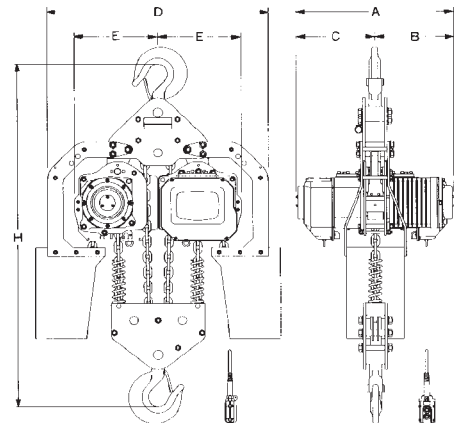

10ton

Specifications

Model	W.L.L. (lbs)	W.L.L. (mt)	Test Load (mt)	Standard Lift (ft)	Load Chain Dia (mm) x Number of Falls	Lifting Motor Output (H.P.) (DB) High:Low Speed	Lifting Speed (ft / min) (DB) High:Low Speed		Minimum Distance H (in)	Ampere (A)	Net Wt. (lbs) 10' : 20'
							50Hz	60Hz			
DA-0.25	550	0.25	0.313	10 20	5.6 x 1	0.68	26	31	20.4	2.5	112 : 116
DA-0.5	1100	0.5	0.625	10 20	6.3 x 1	1.22	24	28	20.8	4.5	123 : 130
DA-1W	2200	1	1.25	10 20	6.3 x 2	1.22-0.41	12	14	27.7	4.5	139 : 152
DA-1S	2200	1	1.25	10 20	7.1 x 1	2.31	22	27	23	8.7	158 : 168
DA-1.5	3500	1.5	1.88	10 20	9.5 x 1	4.62	29	34	28.7	15.3	265 : 280
DA-2W	4400	2	2.5	10 20	7.1 x 2	2.31	11	13	31	8.7	185 : 201
DA-2S	4400	2	2.5	10 20	11.2 x 1	4.62	23	27	28.7	15.3	273 : 293
DA-2.5	5500	2.5	3.13	13	11.2 x 1	4.62	18	21	28.7	15.3	282
DA-3	6600	3	3.75	13	9.5 x 2	4.62	14	17	37	15.3	320
DA-5	11000	5	6.25	13	11.2 x 2	4.62	9	11	40.5	15.3	359
DA-10	22000	10	12.5	13	11.2 x 4	4.62 x 2	9	10	54.7	15.3	873
DB-0.25	550	0.25	0.313	10 20	5.6 x 1	0.68 : 0.23	26 : 9	31 : 10	20.4	2.6	123 : 130
DB-0.5	1100	0.5	0.625	10 20	6.3 x 1	1.22 : 0.41	24 : 8	28 : 9	20.8	4.7	137 : 146
DB-1W	2200	1	1.25	10 20	6.3 x 2	1.22 : 0.41	12 : 4	14 : 5	27.7	4.7	152 : 168
DB-1S	2200	1	1.25	10 20	7.1 x 1	2.31 : 0.77	22 : 7	27 : 9	23	9.2	174 : 185
DB-1.5	3500	1.5	1.88	10 20	9.5 x 1	4.62 : 1.55	29 : 10	34 : 11	28.7	16	300 : 317
DB-2W	4400	2	2.5	10 20	7.1 x 2	2.31 : 0.77	11 : 4	13 : 4	31	9.2	203 : 220
DB-2S	4400	2	2.5	10 20	11.2 x 1	4.62 : 1.55	23 : 8	27 : 9	28.7	16	311 : 331
DB-2.5	5500	2.5	3.13	13	11.2 x 1	4.62 : 1.55	18 : 6	21 : 7	28.7	16	317
DB-3	6600	3	3.75	13	9.5 x 2	4.62 : 1.55	14 : 5	17 : 6	37	16	357
DB-5	11000	5	6.25	13	11.2 x 2	4.62 : 1.55	9 : 3	11 : 3	40.5	16	394

* Current ampere depends on the voltage and length of power cord

* The length of power cord 4core cable is 16'

* Standard push button cord is 2' less than lift

* If you require 6 button pendant control in place of 4 button, a "C" should be added to the end of the model name

Dimensions (in)

Model	A	B	C	D	E	F
DA / DB-0.25	20.7 / 22.1	10.5 / 10.8	10.2 / 11.3	10.8	6.6	4.2
DA / DB-0.5	20.7 / 23.2	10.5 / 11.9	10.2 / 11.3	10.8	6.6	4.2
DA / DB-1W	20.7 / 23.2	10.5 / 11.9	10.2 / 11.3	10.8	8.1	2.6
DA / DB-1S	22.2 / 24.3	11.4 / 12.6	10.7 / 11.7	11.8	6.8	5
DA / DB-1.5	25.7 / 28.2	13.4 / 14.6	12.3 / 13.5	14.6	7.8	6.8
DA / DB-2W	22.2 / 24.3	11.4 / 12.6	10.7 / 11.7	11.8	8.6	3.2
DA / DB-2S	25.7 / 28.2	13.4 / 14.6	12.3 / 13.5	14.6	7.8	6.8
DA / DB-2.5	25.7 / 28.2	13.4 / 14.6	12.3 / 13.5	14.6	7.8	6.8
DA / DB-3	25.7 / 28.2	13.4 / 14.6	12.3 / 13.5	14.6	10.1	4.4
DA / DB-5	25.7 / 28.2	13.4 / 14.6	12.3 / 13.5	14.7	10.7	4.02
DA-10	26.9	13.4	13.4	37.8	10.7	*

* The dimensions D and E depends on the lift

* For top and bottom hook specifications see page 41

* Specifications and dimensions are subject to change without notice



2 push button type (DAfØB)
For monorail



2 push button type (DAfØB)
For monorail

4 push button type
(DAfØB)
For crane



4 push button type
(DAfØB)
For crane



Option: Wiring box for saddle
bMagnetic contactor and transformer are included.
bOperating voltage is 24V
bPower cord and operating cord are not included



Option: Wiring box for saddle
bMagnetic contactor and transformer are included.
bOperating voltage is 24V
bPower cord and operating cord are not included

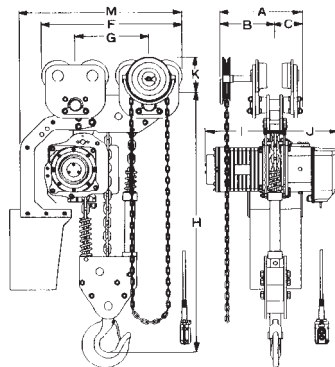

250kgx2.5ton

1x5ton

7.5ton

10ton

Specifications

Model	W.L.L. (lbs)	W.L.L. (mt)	Test Load (mt)	Standard Lift (ft)	Lifting Motor Output (H.P.) (DB) High:Low Speed	Lifting Speed (ft / min) (DB) High:Low Speed		Trolley Traversing Distance on pulling 3' hand chain (in)	Hand Chain Effort [approx.] (lbf)	Minimum Distance H (in)	Traversing Trolley Beam Range (in)	Trolley Min. Radius (in)	Net Wt. (lbs)
						50Hz	60Hz						
DAG-0.25	550	0.25	0.313	10/20	0.68	26	31	4.5	5.5	21.2	2.9 - 4.9	35.4	141
DAG-0.5	1100	0.5	0.625	10/20	1.22	24	28	4.5	11	21.6		35.4	150
DAG-1W	2200	1	1.25	10/20	1.22	12	14	3.7	19.5	28.1		43.3	179
DAG-1S	2200	1	1.25	10/20	2.31	22	27	3.7	19.5	23.4		43.3	196
DAG-1.5	3500	1.5	1.88	10/20	4.62	29	34	3.1	22	28.5	3.9 - 5.9	47.2	320
DAG-2W	4400	2	2.5	10/20	2.31	11	13	3.1	31	30.9		47.2	240
DAG-2S	4400	2	2.5	10/20	4.62	23	27	3.1	31	28.5		47.2	328
DAG-2.5	5500	2.5	3.13	13	4.62	18	21	3.3	39	29.1		66.9	355
DAG-3	6600	3	3.75	13	4.62	14	17	3.3	45	37.4	4.9 - 6.8	66.9	392
DAG-5	11000	5	6.25	13	4.62	9	11	2.8	64	40.9		90.5	472
DAG-7.5	16500	7.5	9.38	13	7.62	6	7	2.4	86	46.6		118.1	825
DAG-10	22000	10	12.5	13	4.62 x 2	9	10	2.4	106	45.8		118.1	1131
DBG-0.25	550	0.25	0.313	10/20	0.68 : 0.23	26 : 9	31 : 10	2.4	6	21.2	2.9 - 4.9	35.4	152
DBG-0.5	1100	0.5	0.625	10/20	1.22 : 0.41	24 : 8	28 : 9	4.5	11	21.6		35.4	165
DBG-1W	2200	1	1.25	10/20	1.22 : 0.41	12 : 4	14 : 5	4.5	20	28.1		43.3	192
DBG-1S	2200	1	1.25	10/20	2.31 : 0.77	22 : 7	27 : 9	3.7	20	23.4		43.3	212
DBG-1.5	3500	1.5	1.88	10/20	4.62 : 1.55	29 : 10	34 : 11	3.7	22	28.5	3.9 - 5.9	47.2	357
DBG-2W	4400	2	2.5	10/20	2.31 : 0.77	11 : 4	13 : 4	3.1	31	30.9		47.2	256
DBG-2S	4400	2	2.5	10/20	4.62 : 1.55	23 : 8	27 : 9	3.1	31	28.5		47.2	366
DBG-2.5	5500	2.5	3.13	13	4.62 : 1.55	18 : 6	21 : 7	3.1	39	29.1		66.9	390
DBG-3	6600	3	3.75	13	4.62 : 1.55	14 : 5	17 : 6	3.3	45	37.4	4.9 - 6.8	66.9	428
DBG-5	11000	5	6.25	13	4.62 : 1.55	9 : 3	11 : 3	3.3	64	40.9		90.5	509

- * Current ampere depends on the voltage and length of power cord
- * The length of power cord 4core cable is 16'
- * Standard push button cord is 2' less than lift
- * If you require 6 button pendant control in place of 4 button, a "C" should be added to the end of the model name
- * Contact the factory for special trolley beam flange widths

DIMENSIONS (* the following measurements are metric)

MODEL	A	B	C	γ	D	E	F	G	I	J	K	M
DAG-0.25/DBG-0.25	344	218+β	126-β	75	168	108	190	100	267/276	261/287	92	
DAG-0.5/DBG-0.5	344	218+β	126-β	75	168	108	190	100	267/303	261/287	92	
DAG-1W/DBG-1W	349	223+β	126-β	75	208	68	221	116	267/303	261/287	104	
DAG-1S/DBG-1S	349	223+β	126-β	75	174	127	221	116	290/321	274/298	104	
DAG-1.5/DBG-1.5	380	236+β	144-β	100	198	174	259	136	342/372	313/345	134	
DAG-2W/DBG-2W	380	236+β	144-β	100	219	82	259	136	290/321	274/298	134	
DAG-2S/DBG-2S	380	236+β	144-β	100	198	174	259	136	342/372	313/345	134	
DAG-2.5/DBG-2.5	385	237+β	148-β	100	198	174	288	150	342/372	313/345	142	
DAG-3/DBG-3	385	237+β	148-β	100	258	114	288	150	342/372	313/345	142	
DAG-5/DBG-5	452	255+β	166-β	125	273	102	327	169	342/372	313/345	167	
DAG-7.5 · DAG-10	423/596 +2β	255/428 +β	168/168-β	125			687	360	342	313/342	167	793/960

- 1) The dimensions D,E depends on the lift. 2) For the dimensions β and γ, see page 38-39.
- 3) The dimension K is in case of that "Traversing l beam width" is minimum.

*The specification and dimensions may be changed without prior notice for improvement.





ELECTRIC CHAIN BLOCK WITH PLAIN TROLLEY

2 push button type (DA·DB)
For monorail



4 push button type
(DA·DB)
For crane



2 push button type (DA·DB)
For monorail

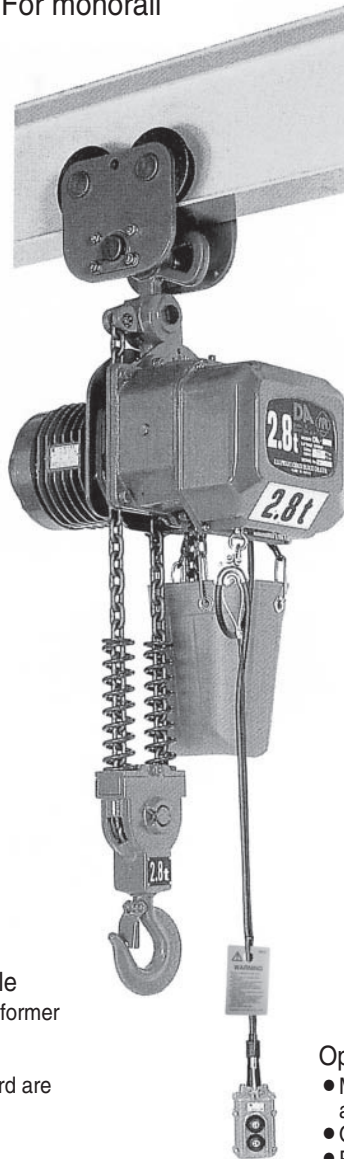

4 push button type
(DA·DB)
For crane



Option:Wiring box for saddle

- Magnetic contactor and transformer are included.
- Operating voltage is 24V
- Power cord and operating cord are not included

Option:Wiring box for saddle

- Magnetic contactor and transformer are included.
- Operating voltage is 24V
- Power cord and operating cord are not included

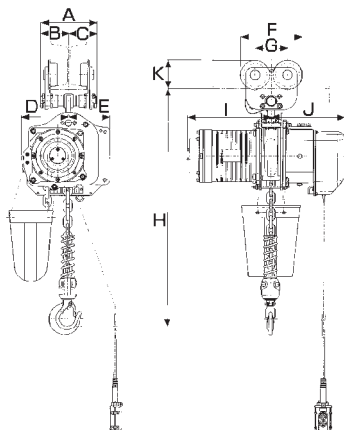

250kg~2.5ton

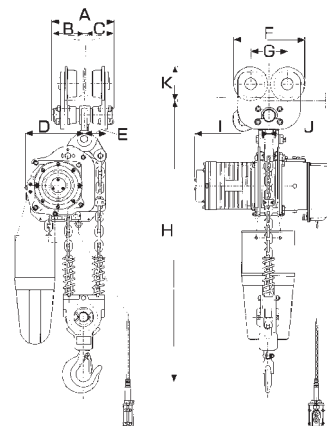

1w~5ton

Specifications

Model	W.L.L. (lbs)	W.L.L. (mt)	Test Load (mt)	Standard Lift (ft)	Lifting Motor Output (H.P.) (DB) High:Low Speed	Lifting Speed (ft / min) (DB) High:Low Speed		Minimum Distance H (in)	Traversing Trolley Beam Range (in)	Trolley Min. Radius (in)	Net Wt. (lbs)
						50Hz	60Hz				
DAP-0.25	550	0.25	0.313	10 20	0.68	26	31	21.2	2.9 - 4.9	35.4	128
DAP-0.5	1100	0.5	0.625	10 20	1.22	24	28	21.6		35.4	139
DAP-1W	2200	1	1.25	10 20	1.22	12	14	28.1		43.3	161
DAP-1S	2200	1	1.25	10 20	2.31	22	27	23.4		43.3	179
DAP-1.5	3500	1.5	1.88	10 20	4.62	29	34	28.5	3.9 - 5.9	47.2	302
DAP-2W	4400	2	2.5	10 20	2.31	11	13	30.9		47.2	220
DAP-2S	4400	2	2.5	10 20	4.62	23	27	28.5		47.2	309
DAP-2.5	5500	2.5	3.13	13	4.62	18	21	29.1		66.9	335
DAP-3	6600	3	3.75	13	4.62	14	17	37.4		66.9	373
DAP-5	11000	5	6.25	13	4.62	9	11	40.9	4.9 - 6.8	90.5	452
DBP-0.25	550	0.25	0.313	10 20	0.68 : 0.23	26 : 9	31 : 10	21.2	2.9 - 4.9	35.4	141
DBP-0.5	1100	0.5	0.625	10 20	1.22 : 0.41	24 : 8	28 : 9	21.6		35.4	152
DBP-1W	2200	1	1.25	10 20	1.22 : 0.41	12 : 4	14 : 5	28.1		43.3	174
DBP-1S	2200	1	1.25	10 20	2.31 : 0.77	22 : 7	27 : 9	23.4		43.3	196
DBP-1.5	3500	1.5	1.88	10 20	4.62 : 1.55	29 : 10	34 : 11	28.5	3.9 - 5.9	47.2	337
DBP-2W	4400	2	2.5	10 20	2.31 : 0.77	11 : 4	13 : 4	30.9		47.2	238
DBP-2S	4400	2	2.5	10 20	4.62 : 1.55	23 : 8	27 : 9	28.5		47.2	346
DBP-2.5	5500	2.5	3.13	13	4.62 : 1.55	18 : 6	21 : 7	29.1		66.9	370
DBP-3	6600	3	3.75	13	4.62 : 1.55	14 : 5	17 : 6	37.4		66.9	408
DBP-5	11000	5	6.25	13	4.62 : 1.55	9 : 3	11 : 3	40.9	4.9 - 6.8	90.5	487

* Current ampere depends on the voltage and length of power cord

* The length of power cord 4core cable is 16'

* Standard push button cord is 2' less than lift

* If you require 6 button pendant control in place of 4 button, a "C" should be added to the end of the model name

* Contact the factory for special trolley beam flange widths

DIMENSIONS (* the following measurements are metric)

MODEL	A	B	C	γ	D	E	F	G	I	J	K
DAP-0.25/DBP-0.25	201	75+β	126-β	75	168	108	190	100	267/276	261/287	92
DAP-0.5/DBP-0.5	201	75+β	126-β	75	168	108	190	100	267/303	261/287	92
DAP-1W/DBP-1W	199	73+β	126-β	75	208	68	221	116	267/303	261/287	104
DAP-1S/DBP-1S	199	73+β	126-β	75	174	127	221	116	290/321	274/298	104
DAP-1.5/DBP-1.5	238	94+β	144-β	100	198	174	259	136	342/372	313/345	134
DAP-2W/DBP-2W	238	94+β	144-β	100	219	82	259	136	290/321	274/298	134
DAP-2S/DBP-2S	238	94+β	144-β	100	198	174	259	136	342/372	313/345	134
DAP-2.5/DBP-2.5	246	98+β	148-β	100	198	174	288	150	342/372	313/345	142
DAP-3/DBP-3	246	98+β	148-β	100	258	114	288	150	342/372	313/345	142
DAP-5/DBP-5	289	123+β	166-β	125	273	102	327	169	342/372	313/345	167

1) The dimensions D,E depends on the lift. 2) For the dimensions β and γ, see page 38-39.

3) The dimension K is in case of that "Traversing I beam width" is minimum.

* The specification and dimensions may be changed without prior notice for improvement.

For "Combination of Electric Trolleys with Traversing Rails", the following must be taken note of:

At the medium row of the table:

In the case of the combination indicated with a gray zone, the relation $H \leq K$ applies to both plain trolley and geared trolley.

In the case of the combination indicated with a blue zone, the relation $H \leq K$ applies only to the geared trolley.

* The dimensions A, B, C of the trolley will vary with the change of the traversing rail's width to be used.

The figure β in the Table can be obtained from the following equation: $\beta = 1/2x[\text{width}(\text{mm}) \text{ of the traversing rail} - \gamma]$

NOTES ON THE WIRING DIAGRAM

- Our electric chain blocks(with the trolleys included), either DA type or DB type, are usually designed to operate on the 3-phase power source.

The electrical parts used for our chain blocks are all the precision ones which can normally operate even with an accidental voltage drop (with a 10% reduction of the rated voltage)

- As standard, our lifting motor (LM) and trolley motor (TM) are respectively assured of the following ratings.

	Kind of Insulation	Short time duty	Intermittent duty
LM	E	30 minutes	40% ED, Number of starts : 240/h
TM	E	15 minutes	25% ED, Number of starts : 240/h

In the case of the DB type, however, its rating will be like:

Short time duty		Intermittent duty	
High speed	Low speed	High speed	Low speed
30 minutes	15 minutes	40% ED, Number of starts : 240/h	20% ED, Number of starts : 120/h

- As to the 4-core power cord, or the 7-core cabtyre cord used for the DAGC, DBGC, DAPC or DBPC type, they are each usually of 5m in length. The cords of other length than the above, or of special dimensions, are available upon request.

- When connecting the power cord to the power source, take care of its correct phase so that the lifting motor can rotate in UP direction and DN direction according to the push of the UP button and DN button on the control switch. If the connection phase is reversed, the negative phase protector starts to work to prevent the lifting motor from rotating in either direction. If this occurs, exchange the connection phase of the black and red leads from each other: at the time, avoid changing the wire connections in the control switch, chain block and trolley.

- The running direction of the electric trolley and/or the saddle has been decided at the shipment, and it may be changed, at your site, by changing the wire connection at the control switch case.

HOIST CLASSIFICATION

	JIS/ISO classification	FEM classification	ASME classification	International protection
DA	M5	2m	H3	IP54
DB	M5	2m	H3	IP54

* The specification and dimensions may be changed without prior notice for improvement.

DEFINITION OF WORDS

Lift and Length of Pushbutton Switch Cord

As the electric chain block is operated, its bottom hook moves up and down and the longest distance of this motion is called a "lift". In other words, the lift refers to the distance between the bottom hook's highest position (with the upper limit switch actuated) and its lowest position (with the lower limit switch actuated). The length of the pushbutton switch cord refers to the distance between the bottom of dimension L and the lower surface of the pushbutton switch case.

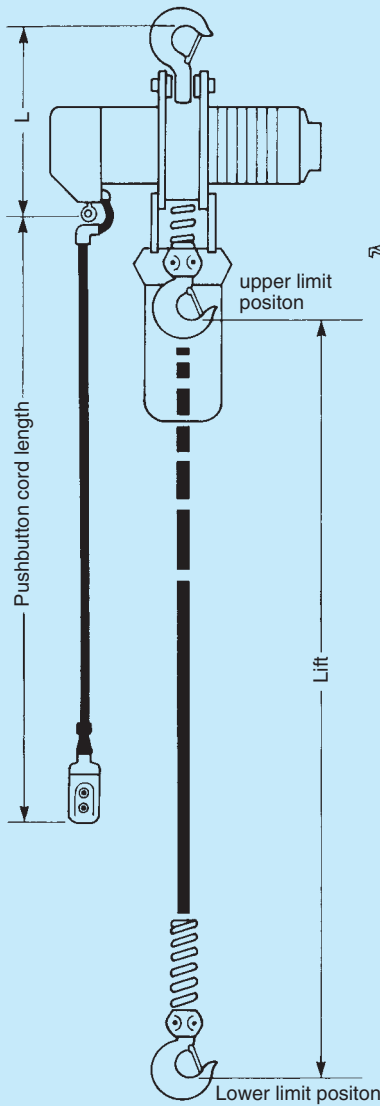

Traversing, Traveling with Trolley and Saddle.

The electric chain block, while hoisting any of loads, may be moved in lateral or longitudinal direction when used in combination with a trolley or saddles which is fitted on a rail. Usually, the trolley is used for a lateral motion of the electric chain block and saddles for a longitudinal motion of it. And when the chain block moves laterally, we call it as "traversing" and when it moves longitudinally, we call it "traveling". Depending on your job requirements, the ELEPHANT electric chain blocks may be combined with different types of saddles of our own; refer to our catalog "ELEPHANT Electric Saddles".

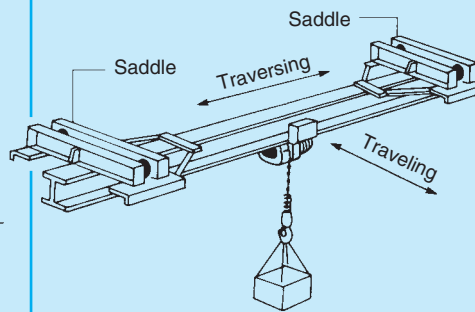

Short Time Duty Rating and Intermittent Duty Rating

As a criterion to indicate the strength and durability of our electric chain blocks. We have specified the ratings of the short time duty and intermittent duty concerning their included electric motors—see the page 12 of catalogs.

• Short Time Duty Rating

"Short time duty rating" means the limited time that the admissible temperature limit of its electric motor won't be exceeded, when the electric chain block is operated continuously on the below cycle.

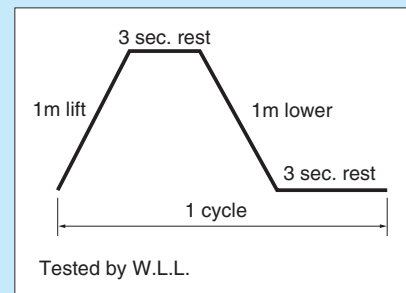

• Intermittent Duty Rating

Compared with "short time duty rating", the temperature of motor rises gradually by properly giving rests to the chain block between its operating periods (lifting and lowering). The percentage duty cycle ED is found as follows.

$$\%ED = \frac{\text{Operating periods}(t_1+t_3)}{\text{Operating} + \text{Rest periods}(T)} \times 100$$

based on the maximum cycle period of 10 minutes. The number of starts/h also affects the rise of temperature. Thus these two factors are specified to show the intermittent duty rating of the electric chain block under the specification of which the electric motor can be operated safely without exceeding its admissible temperature limit.

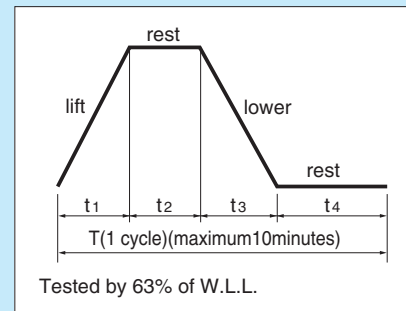

* The specification and dimensions may be changed without prior notice for improvement.

HOOK DIMENSIONS

• BOTTOM HOOK WEIGHT

• LOAD CHAIN WEIGHT

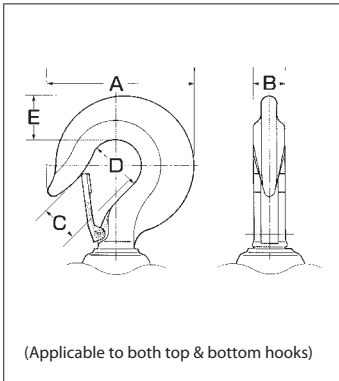

Max working load (mt) & number of falls		0.25	0.49	0.5	1S	1W	1.5	2S	2W	2.5	2S	2W	7.5	10
DIMENSION (in)	A	2.9	3.3		4.05		5.3	5.3	5.3	6.49	7.2	9.0	9.0	
	B	.59	.55		.59		1.0	1.0	1.0	1.37	1.37	1.88	1.88	
	C	1.0	1.0		1.18		1.45	1.45	1.45	1.88	2.28	2.8	2.8	
	D	1.3	1.69		1.96		2.55	2.55	2.55	2.36	2.75	3.3	3.3	
	E	.7	.7		.98		1.37	1.37	1.37	1.9	2.08	2.48	2.48	
Bottom hook weight (lbs)		1.5	1.7	3.7	8	7.7	7.7	12	7.7	25	39	143	176	
No. of fall load chain		1	1	1	2	1	1	2	1	2	2	3	4	
Load chain weight (lbs)	Per 3.2'				1.89		4.3	5.8	2.4	5.86	4.3	5.86	5.86	
	Per 3.2' lift	1.4	1.89	2.4	3.79		4.85		8.6	11.75	17.6	23.5		

Hooks are produced through a hot forging process and so the dimensions may have some errors : ± 2% for 0.25 ~5t hook and ± 3% for the 7.5 and/or 10t hook.

Reading of Model/Code

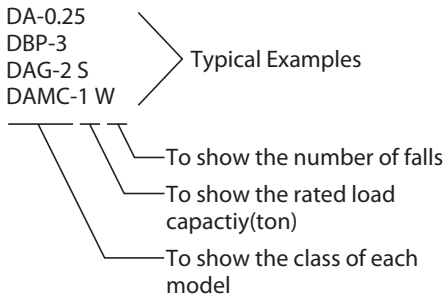

Class code:

It identifies the type (single speed or dual speed type), the number of buttons on the control switches and kinds of trolleys (electric, geared or plain). See the sketches at right.

Rated load capacity:

It shows the rated load capacity(ton) of the relevant chain block.

Number of falls:

It identifies whether the relevant chain block is the 1-fall type or the 2-fall type block(S=1, W=2).

Note: Indication of the number of falls is omitted for certain model in the case where it has been specified according to its rated load capacity.

Class Code

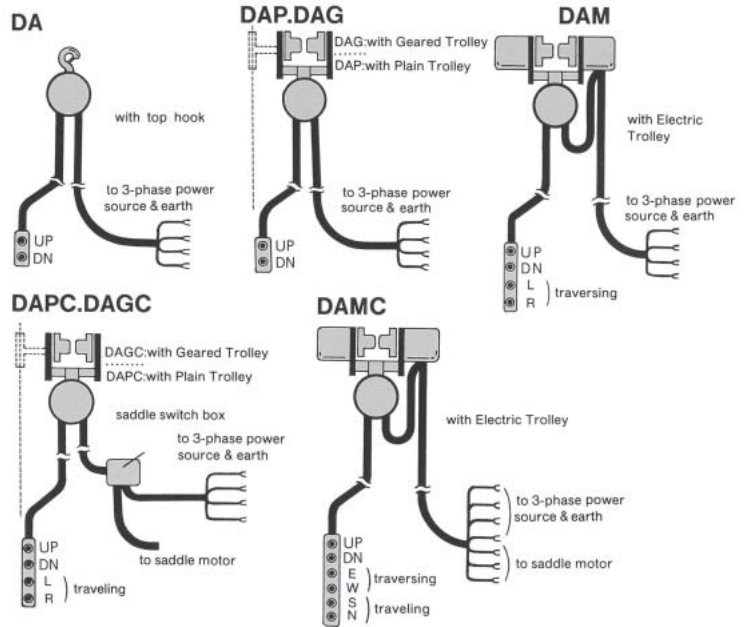

Usually the pushbuttons located on the control switch are labeled as "UP", "DN", "L", "R", "E", "W", "S" and "N". The other types of labeling are available upon request. In the case of the dual speed type (DB type), the chain block can be wound UP and DOWN at either high speed or low speed. The UP and Down buttons are each of push-push type: at the first push, it provided low speed operation and at the second push, it provides high speed operation.

