



Highest Grade Lever Hoist YA

Strongest Load chain ever than before B39 VH

Improved shape of lever

Safety factor 5 times
Load chain, hooks, braking parts have 5 times safety factor.
(0.8t~1.6t)



Patent and copyright registered.

Model	Capacity	Load chain Min. Breaking Load	Safety Factor
YA-80	0.8t	5.2+	6.5
YA-100	1t	5.2+	5.2
YA-160	1.6t	8.3+	5.3
YA-320	3.2t	13.4+	4.2
YA-630	6.3t	26.8+	4.3
YA-900	9t	40.2+	4.5
YA-1200	12t	53.6+	4.2

Single action free spooling
When loading, automatically brakes.

Stronger hook and safety latch
Tip-supporting safety latch brings easy handling.



Specialized manufacturer of highest grade hoist chain

B39 VH, VHC H39 DAT

■ Dimensions (inch)

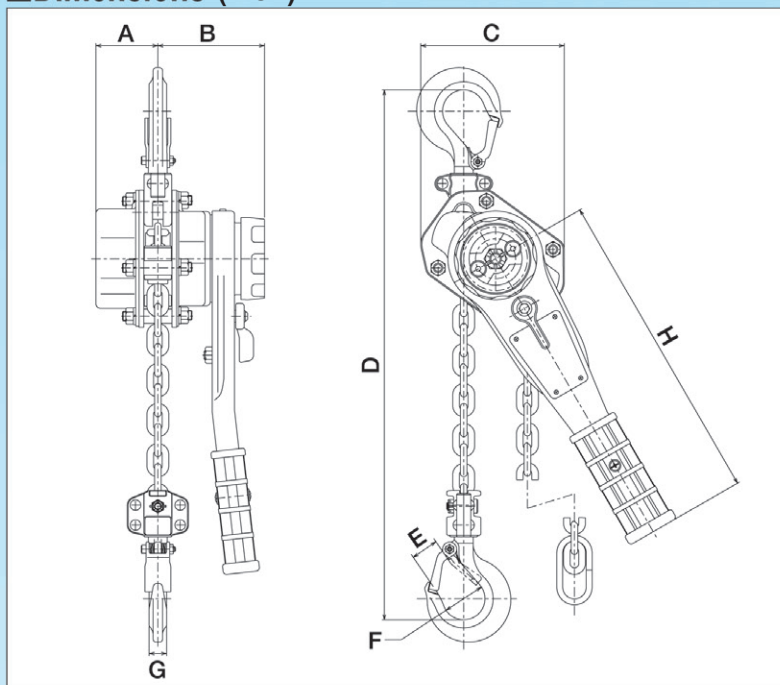

Model	A	B	C	D	E	F	G	H
YA-80	2.1	3.6	4.8	11.4	0.91	1.4	0.59	10.6
YA-100	2.1	3.6	4.8	12.3	1.1	1.7	0.63	10.6
YA-160	2.5	3.9	5.4	13.9	1.2	1.7	0.83	12.2
YA-320	3.3	4.1	7.1	16.2	1.4	2.1	1.1	12.2
YA-630	3.3	4.1	9.3	22.2	1.9	2.8	1.3	12.2
YA-900	3.3	4.1	11.8	27.1	2.9	3.4	1.88	12.2
YA-1200	3.25	4.09	14.57	31.06	2.91	3.35	1.87	12.2

* Specifications & Dimensions are subject to change without notice

■ Specifications

Model	Capacity (lbs)	Capacity (mt)	Standard Lift (ft)	Hand effort to lift full working load (lbf)	Dia. Of load chain x Falls of Chain (mm)	Net weight (lbs)
YA-80	1700	0.8	5	66	5.6	13
YA-100	2200	1	5	82	5.6	14
YA-160	3500	1.6	5	66	7.1	20
YA-320	7000	3.2	5	82	9	34
YA-630	13500	6.3	5	84	9 x 2	59
YA-900	19800	9	5	86	9 x 3	93
YA-1200	26450	12	5	88	9 x 4	159

* Longer lifts available upon request
 * Elephant's hoists have a metric rating
 * Specifications & Dimensions are subject to change without notice

* Test load is 150% of rated load
 * Contact Factory for Info.

Features and performances of the product described in this catalog are designed for their own intended purpose. ELEPHANT will not be held liable for any malfunction, lack of performance or accident if the product is being used in conjunction with any other equipment.

If the product is to be used for unintended purpose, please confirm with your dealer in advance.

All specifications herein are subject to change without notice.



ELEPHANT CHAIN BLOCK CO.,LTD.