

INSTALLATION OF PUSH CRAWLS (Figure 1)

- 1) Measure beam width, add 4-6mm to this figure for clearance Gap "A" between beam and wheel flanges (i.e. 2-3mm on each side).
- 2) Remove and adjust Spacers on the inside of the Side Plate to the outside of the Side Plate on the crosshead to achieve the assembly in Figure 1. Ensure that the amount of spacers are the same on the inside and outside of the Side Plates on all four lock down points of the Crosshead.
- 3) Ensure the Suspension Plate is central to the Side Plates.
- 4) Replace the End Caps with the recess facing the Side Plates and fully tighten down all four Nyloc Nuts.
- 5) Check beam width plus Gap "A" is correct after tightening nuts.

INSTALLATION OF GEARED CRAWL (Figure 2)

Same as for Push Crawls, put the spacers on the outside of the Side Plate should be on the outside of the Push Side Plate only, to allow for an air Gap "B" between the Crosshead nuts and the Hand Chain.

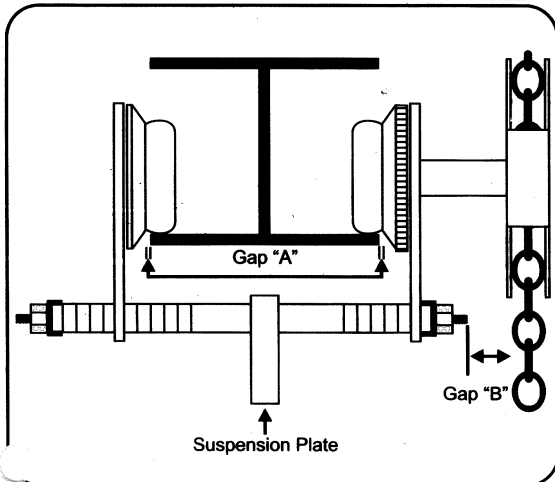

NOTE: Rounded wheel tread is suitable for taper and parallel flanged beams.

MAINTENANCE OF CRAWLS

- Check bearings for play and smooth running.
- Check wheel tread for wear
- Check Crosshead for distortion (Overload).
- Check Suspension Plate for wear on the Hook Seat.

ADD FOR GEARED CRAWL

- Check Vesconite Bush (2) for wear on the Pinion Gear Housing.
- Check wear on Pinion Gear and Spur Gear Teeth.
- Check wear on Hand Chain Wheel Chain Pockets.

CERTIFICATE OF CONFORMANCE

Product Group **Beam Crawl type Manual and Geared**

Beam Crawl Size SWL	Maximum allowable overload factor 1.5 times SWL	Maximum static load (destruct) test factor 4 times SWL
0.5T	0.75T	2T
1T	1.5T	4T
2T	3T	8T
3T	4.5T	12T
5T	7.5T	20T
10T	15T	40T
15 & 20T (with Suspension Plate)	30T	80T

Based on fatigue tests carried out by CSIR South Africa - Certificate Number 000257 A - E.
(Overload and fatigue tests of 60 000 cycles at 1.5 times SWL, Destructive test to 4 times SWL).

This Certificate of Conformance is applicable to all units manufactured with the original components as supplied by the Equipment Manufacturer.

No liability will be accepted for incorrect installation i.e. incorrect tread width assembly, locking nuts not sufficiently tightened, incorrect handling procedure and units failing due to welding accessories to the assembly causing arcing and damage to bearings.

ENSURE YOU KNOW THE WEIGHT OF THE PRODUCT YOU ARE LIFTING BEFORE STARTING TO AVOID DAMAGE TO YOUR EQUIPMENT AND PERSONNEL.