

OPERATOR' S MANUAL

CHAIN BLOCK WITH GEARED TROLLEY

SHG

ELEPHANT CHAIN BLOCK CO.,LTD.



SAFETY PRECAUTIONS

If you use improperly the chain block, the hung load may fall down, causing danger.

Before installing, mounting, operating, using and/or performing maintenance and check, be sure to thoroughly read the Operation Manual so that your chain block is used properly.



Before using your chain block you must become acquainted with your chain block, acquire safety information and understand all the requirements.

This Operation Manual describes the requirements divided into two groups, namely DANGER and CAUTION.

 DANGER	Improper handling may cause danger, resulting in death or heavy injury.
 CAUTION	Improper handling may cause danger, resulting in medium injury or slight injury or only physical damage.

It must be noted here that some cases included in the category of  CAUTION may cause serious results in specific conditions. You must observe strictly the requirements described in the Operation Manual.

Examples of pictorial indications

The square mark  and triangle mark  indicate the description warning against danger or caution. You read concrete description inside the square or triangle.

(The example above shows "CAUTION AGAINST FALLING DOWN".)

The mark  indicates prohibited action. You read concrete description of prohibited action inside the circle or near it.

The explanation mark  indicates required or mandatory action. You read concrete description inside the mark or near it. (This example indicates the unspecified, general obligation of user.)

After use please keep the Manual in the specified place so that any one can use it.

1. General Handling Precautions

⚠ DANGER	
<ul style="list-style-type: none">. Do not allow any person who has not acquired the information described in the Operation Manual and on the caution plates to operate the chain block. ⊘. In no case attempt to hang any load exceeding the rated load.. Never stand under the hung load, and never enter into the hung load moving area. Never carry load over head of person.. Never use the damaged chain block or the noisy chain block.. If the load chain has any one of following irregularities, never use the chain block.<ul style="list-style-type: none">. Torsion, kink, crack or engagement failure. Excessive elongation or wear. Never attempt to modify the chain block and its attachments.	

2. Installation and Mounting



⚠ DANGER	
<ul style="list-style-type: none">. Be sure to perform the check before start of work and the periodic inspection by user.. Installation must be performed only by the specialized contractor or expert having the specific skill and knowledge. ⊘. Never install the chain block in any environment or places where rain or water may affect the chain block.	
⚠ CAUTION	
<ul style="list-style-type: none">. Be sure to install the stopper at the end of lateral traveling or running rails. ⊘. Before installing the chain block ascertain that the chain block installation place has a sufficient strength.. Hung the chain block so that it can swing freely.	

3. Operation and Control





 DANGER

- . Never allow any person to sit on the hung load. 
- . Never leave the hung load.
- . While hanging load, pay attention to it.
- . Never pull obliquely.
 - * Be sure to set once the chain block just above the load, and then hung it.
- . Never engage the hook with building structure, etc.
- . Never invert hung load.
 - * To invert hung load, be sure to use the specific inverting tool. Or hung load inversion must be performed only by the skilled person having the specific knowledge.
- . Before use check that the hand chain moves smoothly. If it does not move smoothly, never use the chain block.
- . Before use check that the brake operates normally.
- . If the brake does not operate normally, never use the chain block.
- . Never perform electric welding of hung load.
- . Never connect ground of welding machine to the load chain.
- . In no case attempt to bring the welding electrode into contact with the load chain.

 CAUTION

- . In no case attempt to use the chain block if its hook stopper has been broken. 
- . Never engage the hung load and hand chain with structure.
- . Be careful so that the chain block or trolley does not hit against the stopper or structure.
- . Never remove the warning labels or caution plates from the chain block. Never leave them illegible.
- . Never use any mechanical operating forces other than manual pulling force.
- . Never throw or drag the chain block.
- . When hoisting, once stop hoisting when the load chain is tightened.
- . When using two or more chain blocks together, ascertain that the load does not exceed the rated load of each of them.
- . Keep the chain block and load chain always clean.
- . Ascertain that the lift is sufficient for the intended work. 
- . Keep the load chain lubricated.

4. Maintenance Check and Modification

 DANGER
<ul style="list-style-type: none">. In no case attempt to use any parts other than the genuine parts supplied by Elephant.. Never cut the load chain, and never add the load chain. 
<ul style="list-style-type: none">. The maintenance check and repair must be performed only by the qualified person. . Before performing maintenance check or repair be sure to ascertain that the chain block is free from load.. If any abnormality is found in maintenance check, repair the chain block without delay before use.
 CAUTION
<ul style="list-style-type: none">. Before performing the maintenance check or repair be sure to put up the indication board "UNDER CHECK", indicating that work is being performed. 

***Note:**

- . Before doing any inspection which needs disassembling and assembling, be sure to contact the dealer or Elephant's office.

CHECK THE FOLLOWING BEFORE USE

1. Visually check to make sure that the chain block is not deformed and no part has been lost.
2. Check the installation state.
 - * Chain block and load chain
 - * Load chain and bottom hook fixture (idle wheel)
 - * Bottom hook fixture and bottom hook
3. Make sure that the chain fixing bolts are fitted properly.
4. Pulling the hand chain, check that the load chain is wound smoothly and that the bottom hook assembly moves up and down smoothly. Ascertain that the dog clicks when the chain is wound up.
5. Check that the load chain is sufficiently lubricated and free from flaws.
6. Check that there is no gap between the side plate and the main body, check that there is no deformation, and make sure that the side plate and stay bolt intersection angle (θ) is 90° (see Figure 1 below).
7. Make sure that dirt is not accumulated on the wheel gears.
8. Move the chain block laterally without load to ascertain that no abnormal sound is heard.

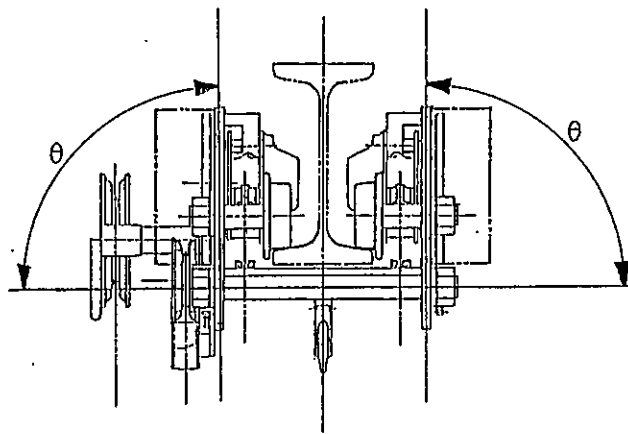
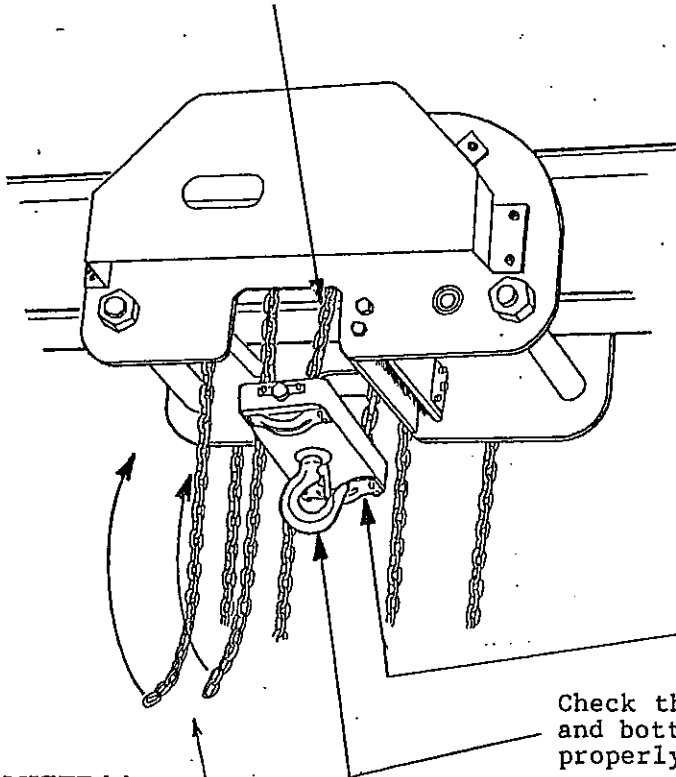

Figure 1

Check that the load chain is sufficiently lubricated and free from flaws.



Check that the load chain and bottom hook fixture (idle wheel) have been installed properly.

Check that the bottom hook fixture and bottom hook have been installed properly.

DANGER!!

Make sure that the chain fixing bolts have been fitted properly.

Never use your chain block without taking proper corrective action if any one of these 8 check points is found to be abnormal. Otherwise serious danger is caused.



INSTALLATION AND USAGE

1. Installation

 DANGER	. If you do not understand the content of Operation Manual and description on the caution plates, never operate the chain block.
	. The structure (building or other structures) on which the chain block is installed must have the load supporting capacity higher than "rated load x 4". When the chain block is used as an auxiliary means for crane, ensure the safety factor 5. * The structure may be broken.

CORRECT USAGE AND CAUTIONS

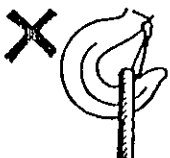
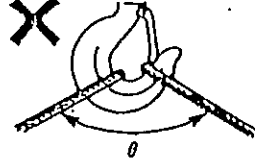
1. Slings

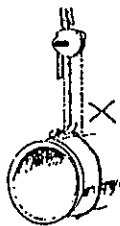
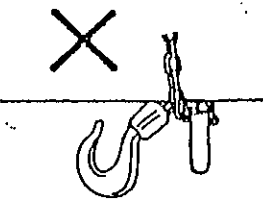
 DANGER	. Before starting work check the slinging tools. . Some slinging procedures are not applicable and dangerous. * The following slinging procedures are very dangerous. Never apply them.
	<p>(1) The following hooking (upper and lower) is dangerous. Never apply it.</p> <div style="display: flex; justify-content: space-around; align-items: flex-end;"> <div style="text-align: center;">  <p>The load is not caught correctly or the sling is not set properly.</p> </div> <div style="text-align: center;">  <p>The angle (θ) is too wide. The limit angle is 60°.</p> </div> <div style="text-align: center;">  <p>The stopper malfunctions.</p> </div> <div style="text-align: center;">  <p>The load can not be held by the front end of hook.</p> </div> </div> <p>(2) Never wind the load chain directly around the load. Otherwise the load chain may be broken, irrespective of whether the load is hard or soft, causing serious danger. See Figure 1.</p> <p>If the chain is wound around the hook of vehicle, the strength of chain is reduced down to 1/3 to 1/5, causing danger. See Figure 2.</p> <div style="display: flex; justify-content: space-around; align-items: center;"> <div style="text-align: center;">  <p>Figure 1</p> </div> <div style="text-align: center;">  <p>Figure 2</p> </div> </div>

(3) If the load chain is kinked, straighten it before use. If the load chain is kinked, its holding capacity is reduced. Be sure to straighten it before use. See Figure 3.

If the specified number of load chain sling branches is 2 or more, the bottom hook may pass through two branches, resulting in kink. Return it to its normal position to remove kink. See Figure 4.

If the chain is not kinked, weld seams of chain links are arranged straightly in the same direction.

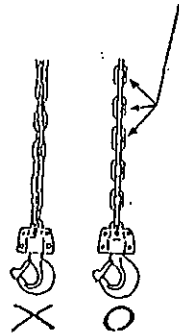
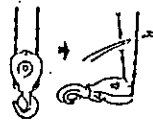

Figure 3



If the bottom hook passes between two branches, the chain is kinked.



Return the bottom hook to its normal position to remove kink.

Figure 4

OPERATING PROCEDURE

* Setting the chain block and adjusting the height of bottom hook

- (1) Move the chain block to a proper position, using the lateral traveling hand chain provided at the left side of chain block. (Move the chain block so that the chain block and the load chain are set vertically when load is hung on the load chain.)
- (2) Lift and lower the bottom hook, using the lifting hand chain provided at the right side of chain block. (To move up the bottom hook, pull down the right-hand hand chain. To move down, pull down the left-hand hand chain.)

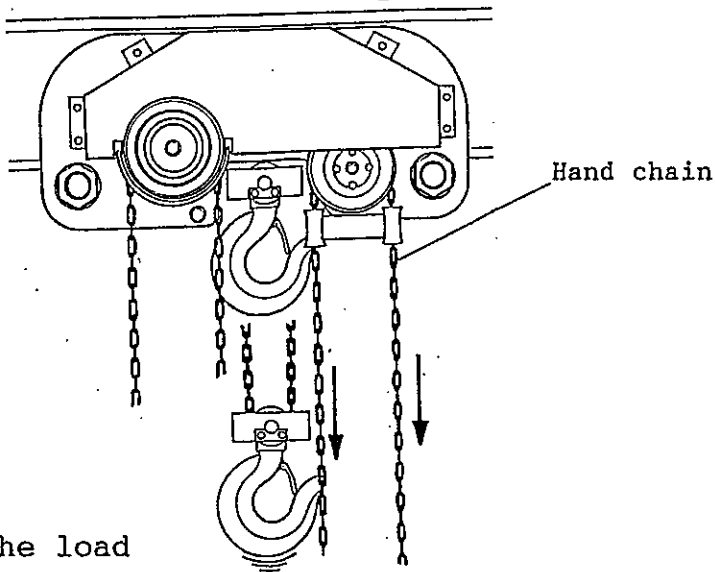

* Setting the load

- (3) For slinging, use the sling tools having proper load carrying capacity and proper length. Pay attention to the load carrying capacity of slinging tools. When slinging, be careful so that undue force is not applied to the hook as shown below.

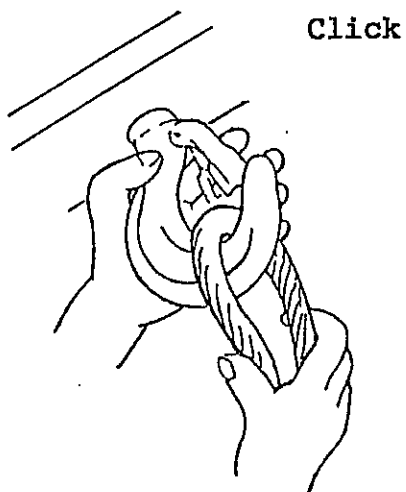

* Figure 5

If the slinging tool is not located in proper position on the hook, the slinging tool may shift while hung up load is carried, resulting in appearance of shock load which causes serious danger.
Once lower the load, and then sling again correctly.

* Figure 6

If two slinging ropes are used and the angle (θ) between ropes is too wide, undue force is applied to the slinging tool, and the stopper may be damaged, and the load may fall down. In this case change the slinging position. Use longer slinging tool if there is a sufficient slinging allowance. (The angle θ must be 60° or less.)

* Figure 7

If the slinging tool is so thick that the stopper cannot restore its initial position, resume the normal function of the stopper, and try.

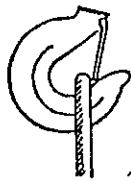

Figure 5

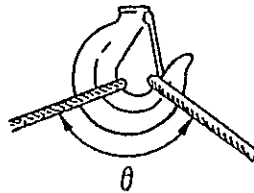

Figure 6

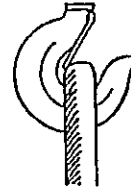

Figure 7

* Lifting and lowering

At first make sure that the load which you want to lift does not exceed the rated load.

When lifting after slinging:

- (1) After the chain block load chain and slinging tool are stretched tightly, check at first the slinging state.
- (2) Slightly lift the load from the ground, and check the load balance.
- (3) Then, lift and lower the chain block several times for several centimeters so as to check that the brake of chain block operates normally.

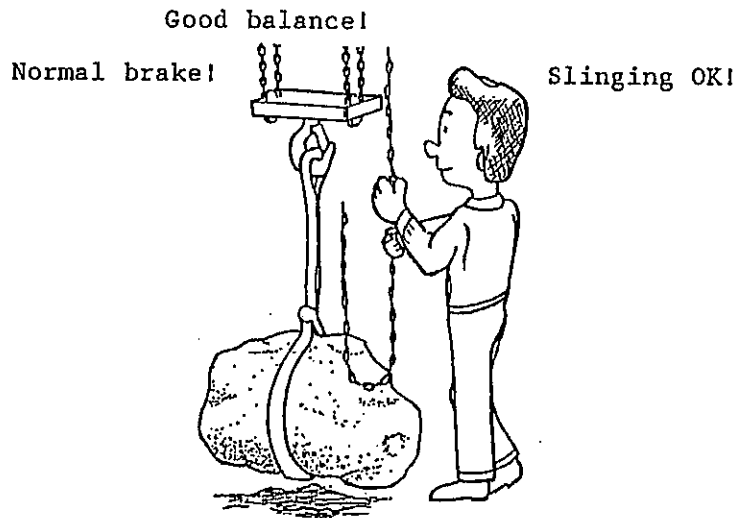

Before lifting the load to a high position, be sure to check the three items stated above.

- . Never stand under the load, and never put your hand or leg under the load.
- . Never leave the lifted load.
- . If any abnormal sound is heard during operating, stop the operation at once, and check the safety.
- . After completion of work unload, and lift the bottom hook to a height 2 m or more from the floor.

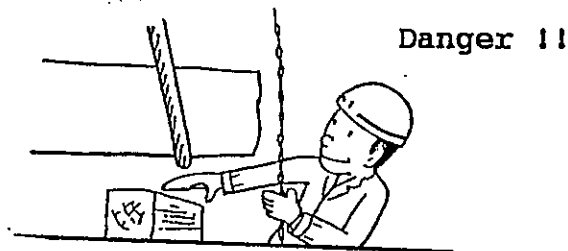

Squeak

Safety check!

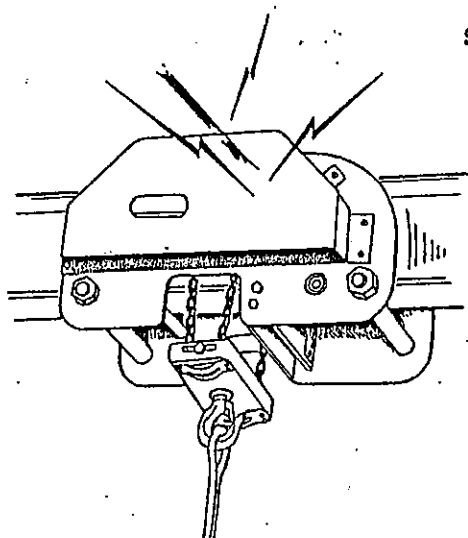

DANGEROUS USES

- Never allow overload.
The rated load is indicated on the name plate attached to the chain block. Real load must not exceed the rated load. The chain block is designed so that the rated load can be lifted by pulling the hand chain with a force 20 to 50 kg. If more pulling force is required to pull the hand chain, this means overload or trouble in the chain block. If the hand chain cannot be pulled easily, never use the chain block since it is very dangerous.

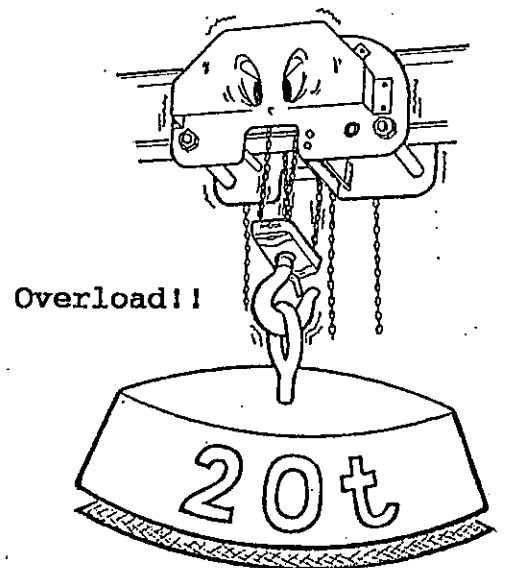

- Never sit on the hung load. Never stand under the hung load.

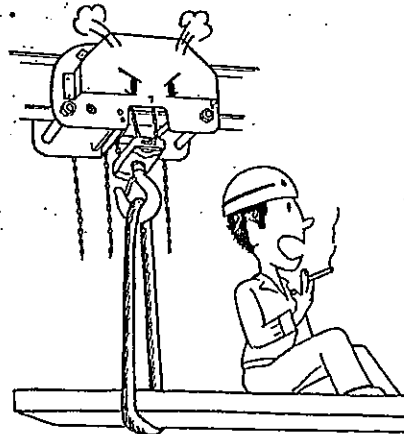

- Prevent the chain block from being affected by shock load. Never operate the chain block, allowing the load to fall down abruptly, causing shock, even when the falling height is small. This may cause serious accident.

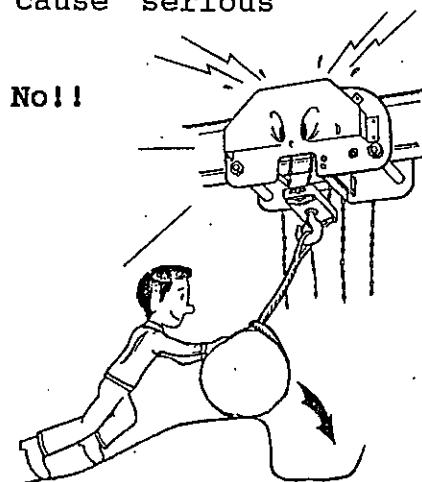

MAINTENANCE AND INSPECTION

 DANGER	<ul style="list-style-type: none"> . Never use any parts and chain block if the use limit is reached. . If excess over the specified use limit is found in the daily check or periodic check, be sure to replace the pertinent part. * Using the part whose use limit has been exceeded cause serious danger.
--	--

1. Load Chain Inspection and Use Limit

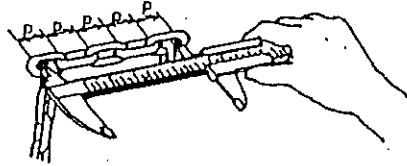

Check the whole load chain with utmost care. To check elongation, measure the inside length of 5 links as shown above. It is advisable to check the load chain with regular intervals of about 50 cm. If elongation of chain is close to the limit, reduce the measurement pitch (intervals) to see that there is no excess over the limit shown in the table. If visual check reveals the influence of heat or any deformation is found, be sure to replace the load chain with new genuine load chain. Never add any chain by welding by yourself.

Rated load - Number of slings	Chain diameter - P x 5 (mm)	New chain P x 5 limit (mm)
0.5 t - 1	$\phi 5 - 75$	77.6
1 t - 1	$\phi 6.3 - 95$	98.3
1.6 t - 1	$\phi 7.1 - 105$	108.6
2 t - 1	$\phi 8 - 120$	124.1
2.5 to - 1	$\phi 9 - 135$	139.6
3 to 3.15 t - 1	$\phi 11.1 - 166.5$	172.2
2 to 3.15 t - 2	$\phi 7.1 - 105$	108.6
5 t - 2	$\phi 9 - 135$	139.6
7.5 t - 3	$\phi 9 - 135$	139.6
10 t - 4	$\phi 9 - 135$	139.6
15 to 16 t - 5	$\phi 11.1 - 166.5$	172.2
20 t - 6	$\phi 11.1 - 166.5$	172.2
30 to 31.5 t - 10	$\phi 11.1 - 166.5$	172.2

2. Hook Inspection and Use Limit

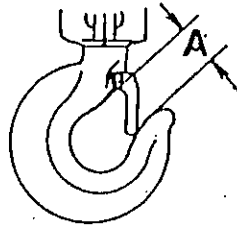

- . If the size A of hook exceeds the value shown in the table, replace the hook with the new genuine hook. Never repair the hook. Never weld any piece to the hook. Otherwise serious danger is caused.
- . Disassemble the bottom hook chain fixing bolt. If wear, bend, or crack is found, replace the bolt with new one.
- * When reassembling, be sure to fit the cotter pin.

Rated load (t) - Number of slings	0.5 - 1	1 - 1	1.6 - 1	2 - 1	2.5 - 1	3 to 3.15 - 1	3 to 3.15 - 2
New hook, size A (mm)	30	34	39	43	45	43	
Limit size A (mm)	31.5	35.7	40.9	45.2	47.3	45.2	50
	5 - 2	7.5 - 3	10 - 4	15 to 16 - 5	20 - 6	30 to 31.5 - 10	52.5
	58	70	70	80	80	120	
	60.9	73.5	73.5	84.0	84.0	126.0	

* Plain roller and gear roller wheel

If the following phenomena appear, replace the roller wheel.

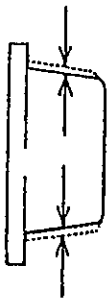
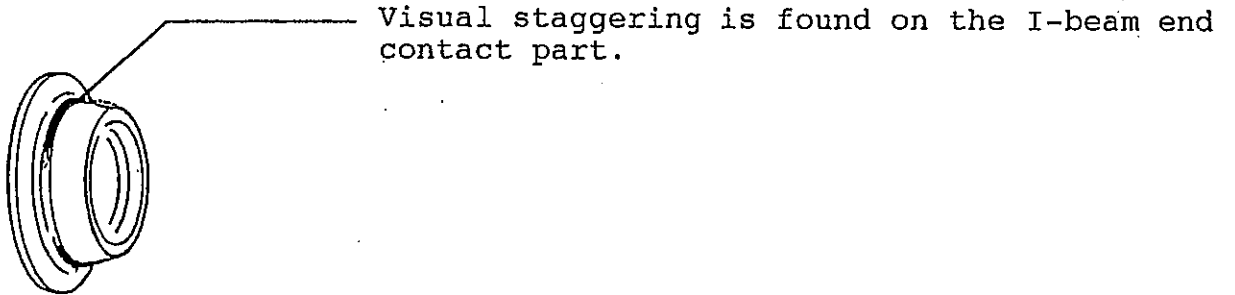



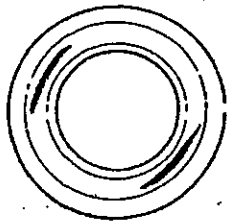

Wear exceeding 5% of initial diameter



Visual uneven wear on tread (visual wear)

CHAIN BLOCK USE STANDARD AND CHECK STANDARD (REFER TO JIS B 8802)

 DANGER (1. USE STANDARD)	
(When using the chain block, follow the instructions given below.)	
1. Make sure that the chain block which you use is suited to the use conditions. 2. Never use the chain block to hang load exceeding the rated load, excepting tests. 3. Never use any unspecified load chain for the chain block.  4. Never use the chain block having insufficient lift. 5. Never use the bottom hook if it does not have fixture or the stopper is not effective. 6. Never use the chain block if its chain fixture has been lost. 7. Never wind the load chain around load. 8. Never hang load on the front end of hook. 9. Never operate quickly the hand chain when lifting or lowering load. 10. Never allow excessive lifting and lowering. 11. Never allow to walk under hung load. 12. Never pull obliquely. 13. Never engage the hook with structures.	
14. Before use make sure that the load chain is free from kink and tangle. If any kink or tangle is found, remove it before use. 15. If the chain block is used at low temperature, high temperature, in corrosive atmosphere or in special conditions, follow the manufacturer's instructions. 16. Users must not modify the chain block. Modification must be made only by the manufacturer. 17. Never leave the load hung for a long time. 	
 CAUTION (USE STANDARD)	
18. Before use perform daily check. 19. If required hand force is felt excessive, stop operation at once.  20. Never drop the chain block. 21. Apply the lubricating oil to the load chain before use. 22. Properly apply the lubricating oil to the gears, bearing and other friction parts. 23. If the chain block is not used for a long time, apply anti-corrosive means and store it. 24. If any unordinary use is intended, contact Elephant in advance.	

2. Check Standard

- 2.1 Use the chain block after completion of daily check (Note 1) and periodic check (Note 2).
- 2.2 The daily check items, checking method and check standard are shown in Table 1 (Note 3). However, if the chain block is used frequently, or unordinary use is intended, check also other items in addition to the specified check items.
- 2.3 The periodic check must conform to Table 1 (Note 3).
- 2.4 When repairing the chain block, check the periodic check items shown in Table 1 (Note 3) after repair, and make sure that the chain block operates normally. Use only the Elephant's genuine parts when replacing the parts.

Notes

- (1) Check before use
- (2) Check which is performed periodically. The periodic check is performed every 6 months or once a year although the frequency varies depending on use frequency.
- (3) The items marked with a circle in Table 1 are checked.

Table 1 Check Standard

Check		Checking items	Checking method	⚠ DANGER Check standard (If the following use limit is reached, replace the part or discard it.)
Daily check	Periodic check			
Indications				
o	o	Indication (name plates)	Visual check	Existence/nonexistence of indications (name plates)
	o	Class of load chain	Visual check	Confirmation of class of load chain
Operation				
o	o	Lifting and lowering operations	Lift and lower without load.	<ol style="list-style-type: none"> 1. Lifting and lowering motions must be smooth. 2. When lifting, the brake dog must click. 3. When lowering, the brake must function normally.
	o	Operation (Note 4)	Rated load	
<p>Note 4: Operation in case of periodic check must be performed after checking of chain block.</p>				
Hook				
o	o	Hook opening	Visual check	Compare with standard size to make sure that there is no deformation (prepare the major size table before use).
o	o	Deformation	Visual check	Bend and distortion are not allowed.
o	o	Deformation of shank	Visual check (daily check), measurement (periodic check)	Remarkable gap must not found between hook fixture and shank.
o	o	Wear, corrosion	Visual check (daily check), measurement (periodic check)	Remarkable wear and corrosion are not allowed.
o	o	Flaw, detrimental defect	Visual check (Note 5)	Crack and other detrimental defects are not allowed.
o	o	Latch	Visual check, operation	Remarkable wear and deformation are not allowed, and operation must be normal.
<p>Note 5: In case of periodic check the magnetic particle flaw test conforming to JIS G 0565 (magnetic particle flaw test of steels and defect indicating magnetic particle pattern classification) or JIS Z 2343 (penetrating flaw test and defect indicating pattern classification).</p>				

Table 1 Check Standard (Continued)

Check		Checking items	Checking method	⚠ DANGER Check standard (If the following use limit is reached, replace the part or discard it.)
Daily check	Periodic check			
Load chain				
o	o	Pitch elongation	Visual check (daily check), measurement (periodic check)	If pitch elongation is 5% or more, never use the load chain. (Prepare the major size table before use.)
o	o	Wear	Visual check (daily check)	If wire wear (diameter) is 10% or more, never use the load chain.
o	o	Deformation	Visual check	Deformation is not allowed.
o	o	Flaw and other detrimental defects	Visual check (Note 5)	Crack and other detrimental defects are not allowed.
o	o	Corrosion	Visual check	Remarkable rust is not allowed.
Hand chain				
		Hand chain	Visual check or measurement	Remarkable pitch elongation and deformation are not allowed.
Main Body				
o	o	Frame	Visual check	Deformation and remarkable corrosion are not allowed.
o	o	Gear box	Visual check	Deformation and remarkable corrosion are not allowed.
	o	Gear	Disassemble, and visually check or measure.	1. Remarkable wear is not allowed. 2. Breakage is not allowed.
	o	Load sheave, idle wheel	Disassemble, and visually check or measure.	1. Remarkable wear and deformation are not allowed. 2. Crack and damage are not allowed.
	o	Hand chain wheel	Disassemble, and visually check or measure.	1. Remarkable wear and deformation are not allowed. 2. Flaw and damage are not allowed.
	o	Bearing	Visual check or measurement	Wear, crack, damage and other detrimental defects are not allowed.
o	o	Chain stopper	Disassemble, and visually check.	Deformation and bolt/nut loosening are not allowed.

Table 1 Check Standard (Continued)

Check		Checking items	Checking method	⚠ DANGER Check standard (If the following use limit is reached, replace the part or discard it.)
Daily check	Periodic check			
Bolts and Nuts				
o	o	Bolts, nuts, rivets and cotter pins	Visual check	<ol style="list-style-type: none"> 1. In case of daily check that the nuts, rivets and copper pins which are visible from outside are not lost, and that the nuts and rivets are not loosened. 2. In case of periodic check make sure that the external parts and internal parts (mentioned above) are normal.
Brake				
	o	Wear of brake lining	Measure.	Remarkable wear is not allowed (according to manufacturer's instructions).
	o	Brake screw	Visual check or measurement	Remarkable wear is not allowed.
	o	Pawl and ratchet wheel	Visual check or measurement	Remarkable wear is not allowed.
Others				
	o	Others	Visual check or measurement	Other defect affecting adversely use is not allowed.